

# PROIEZIONE ORTOGONALE DELLA SEZIONE DI UNA PIRAMIDE CON UN PIANO ORIZZONTALE

## #PASSOPASSO

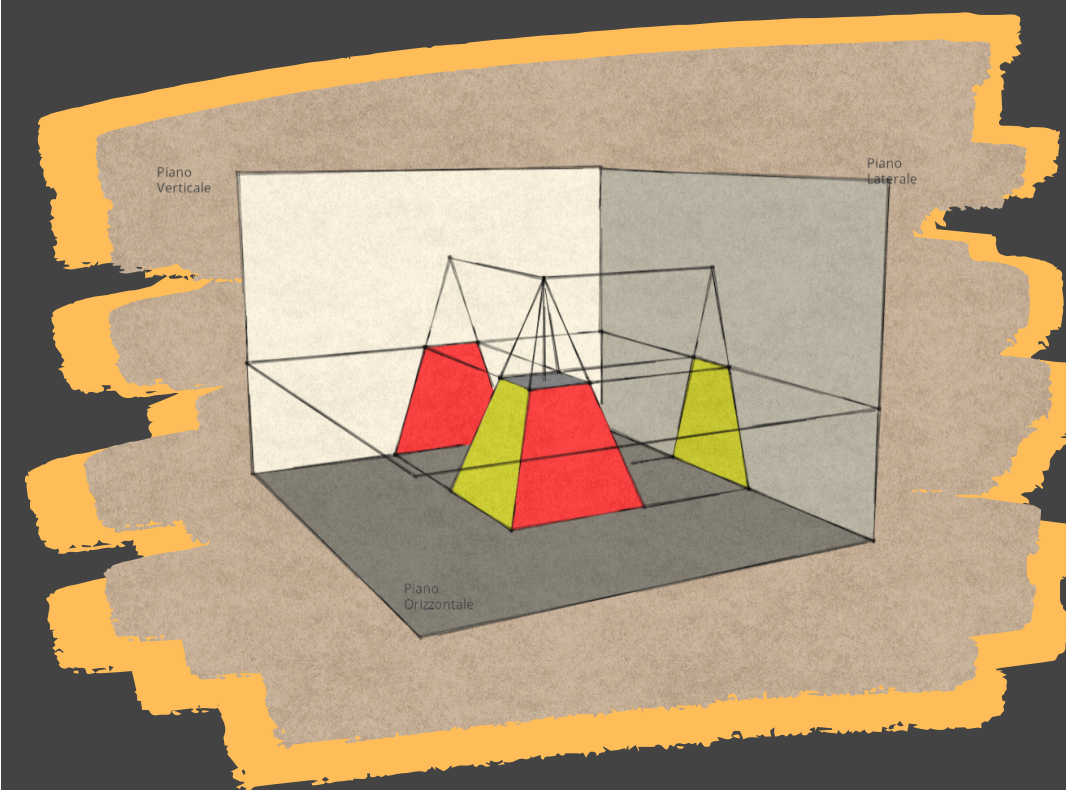

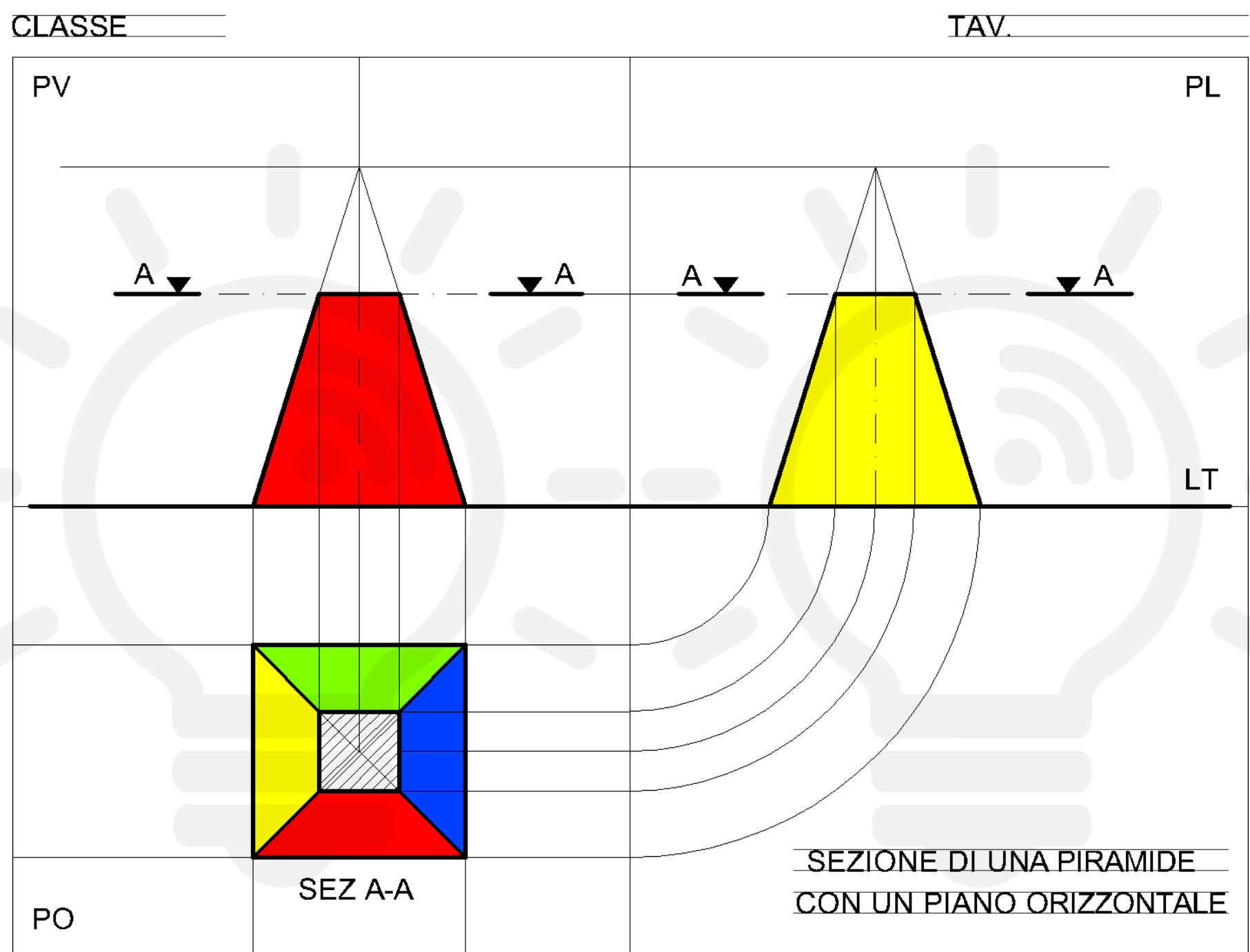
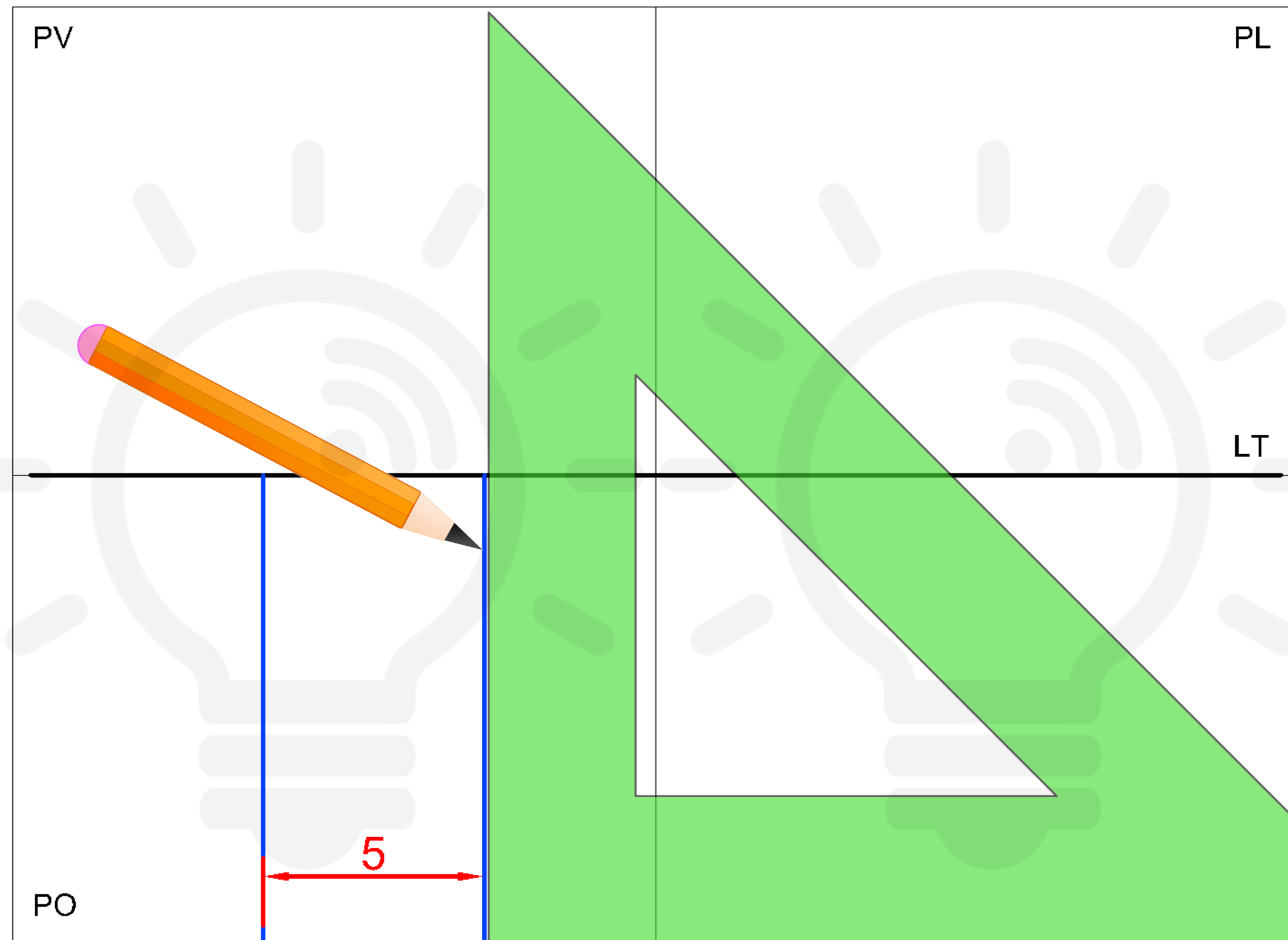

TECNOLOGIA DUEPUNTOZERO



Inizia con la **vista dall'alto**. Traccia due **linee verticali** distanti **5 cm** tra loro. Cerca di occupare al meglio lo spazio a disposizione

CLASSE \_\_\_\_\_

TAV. \_\_\_\_\_

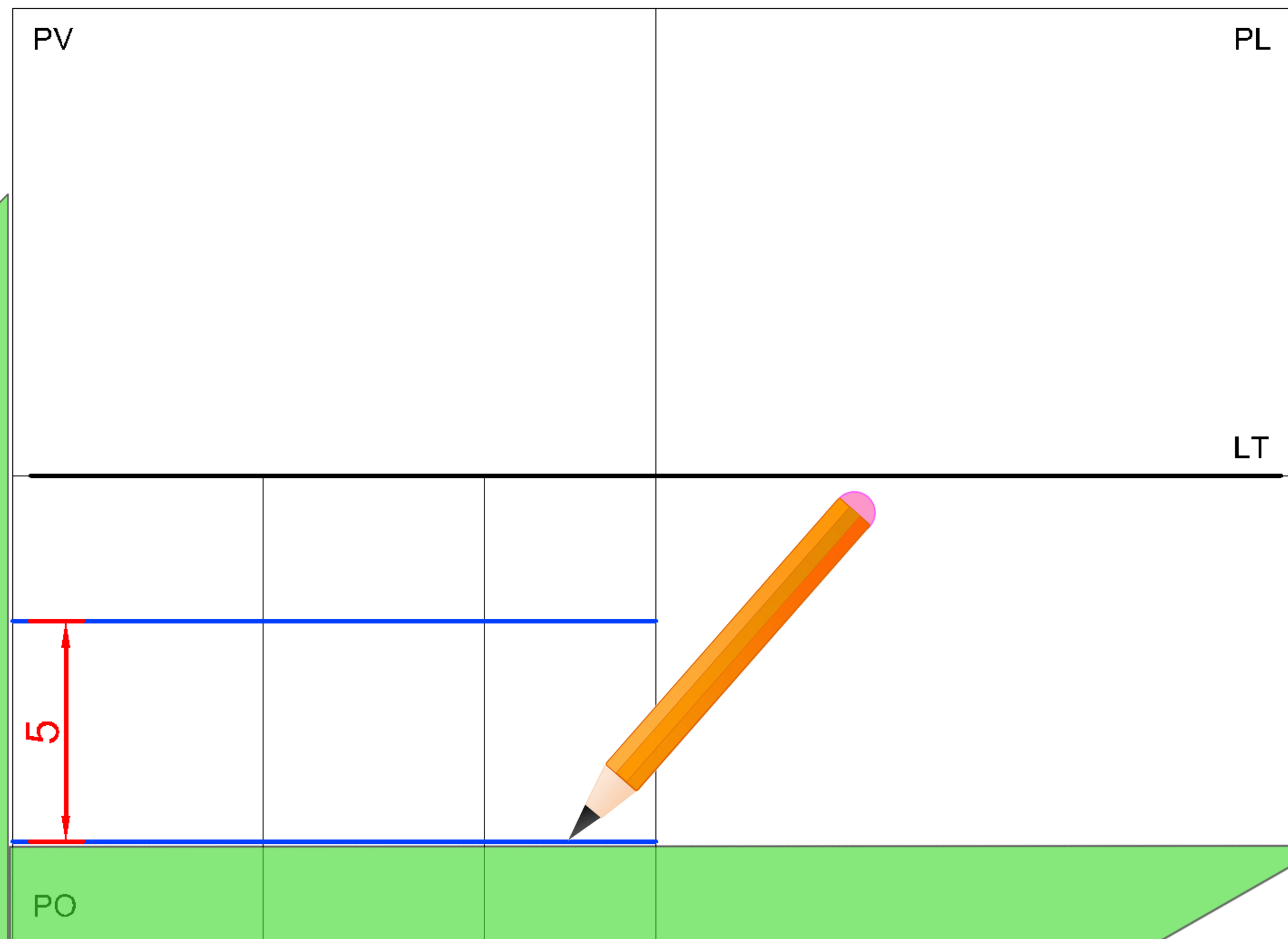

TECNOLOGIA DUEPUNTOZERO

2



Traccia due **linee orizzontali** distanti **5 cm** tra loro per trovare la base quadrata della piramide

CLASSE \_\_\_\_\_

TAV. \_\_\_\_\_

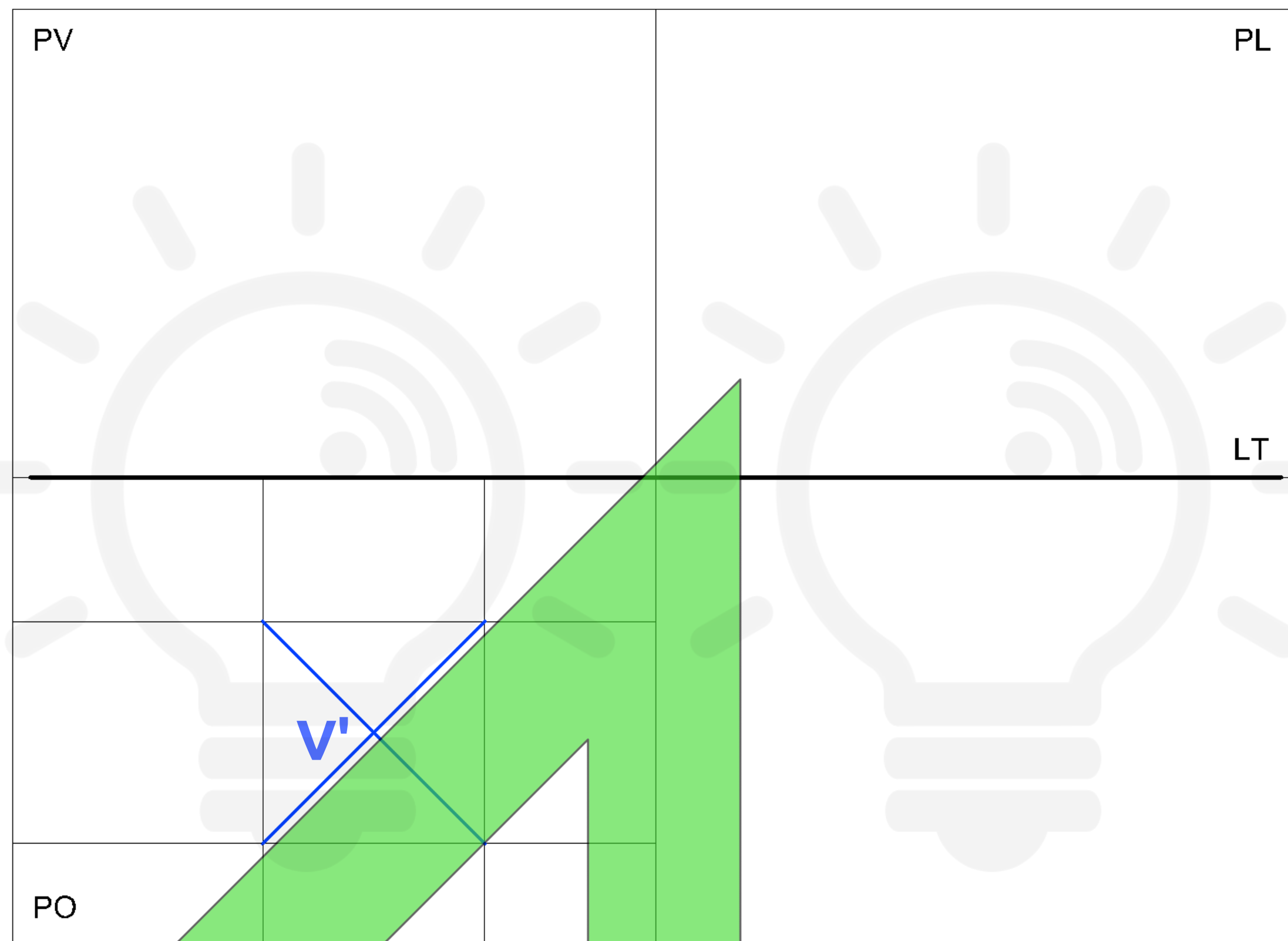

TECNOLOGIA DUEPUNTOZERO

3



**Completa la pianta**, traccian le **diagonali del quadrato**:  
rappresentano gli spigoli che convergono nel vertice V della piramide

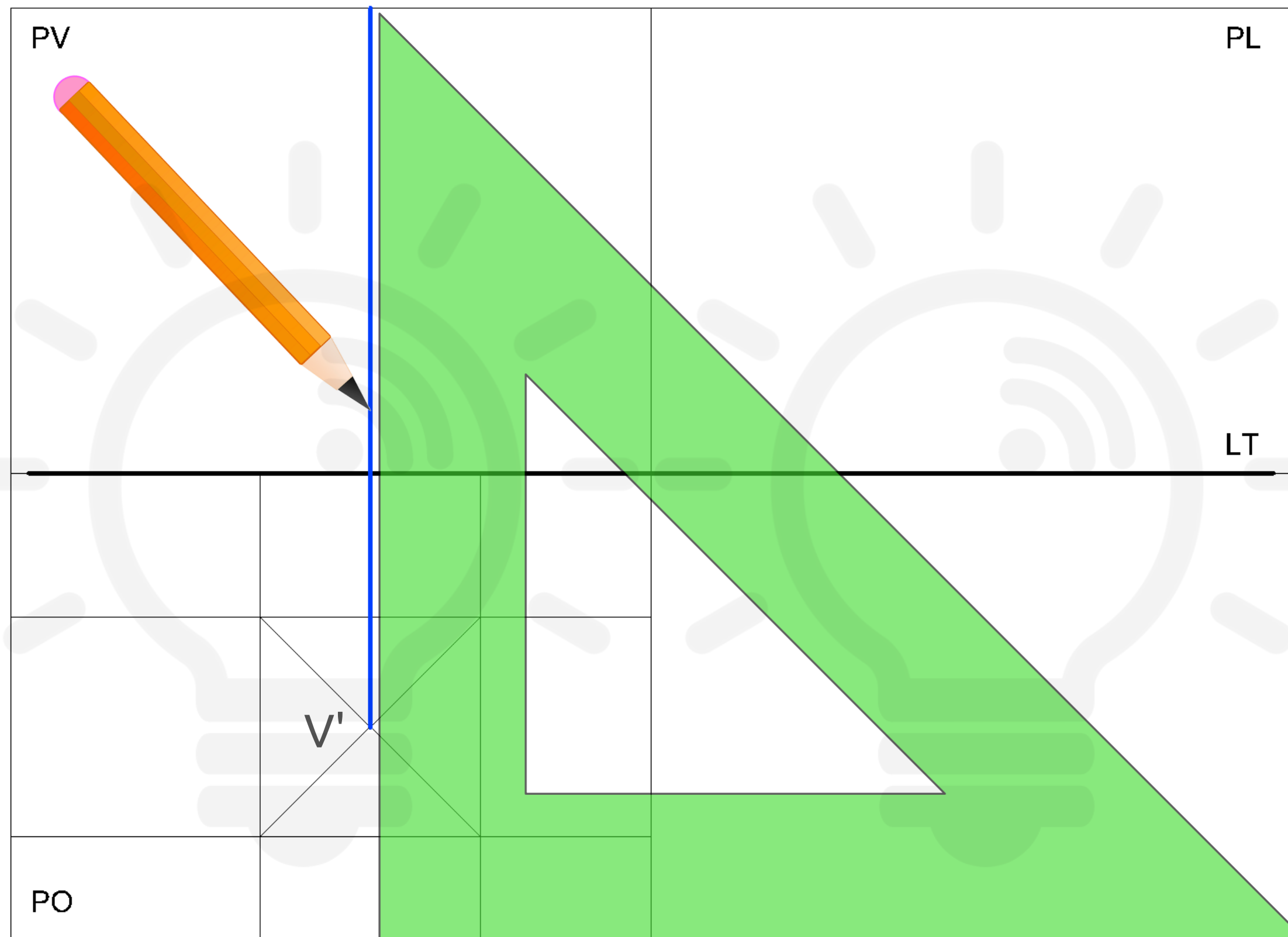

TECNOLOGIA DUEPUNTOZERO

**Traccia le linee di proiezione dalla pianta**  
per costruire la vista vista frontale

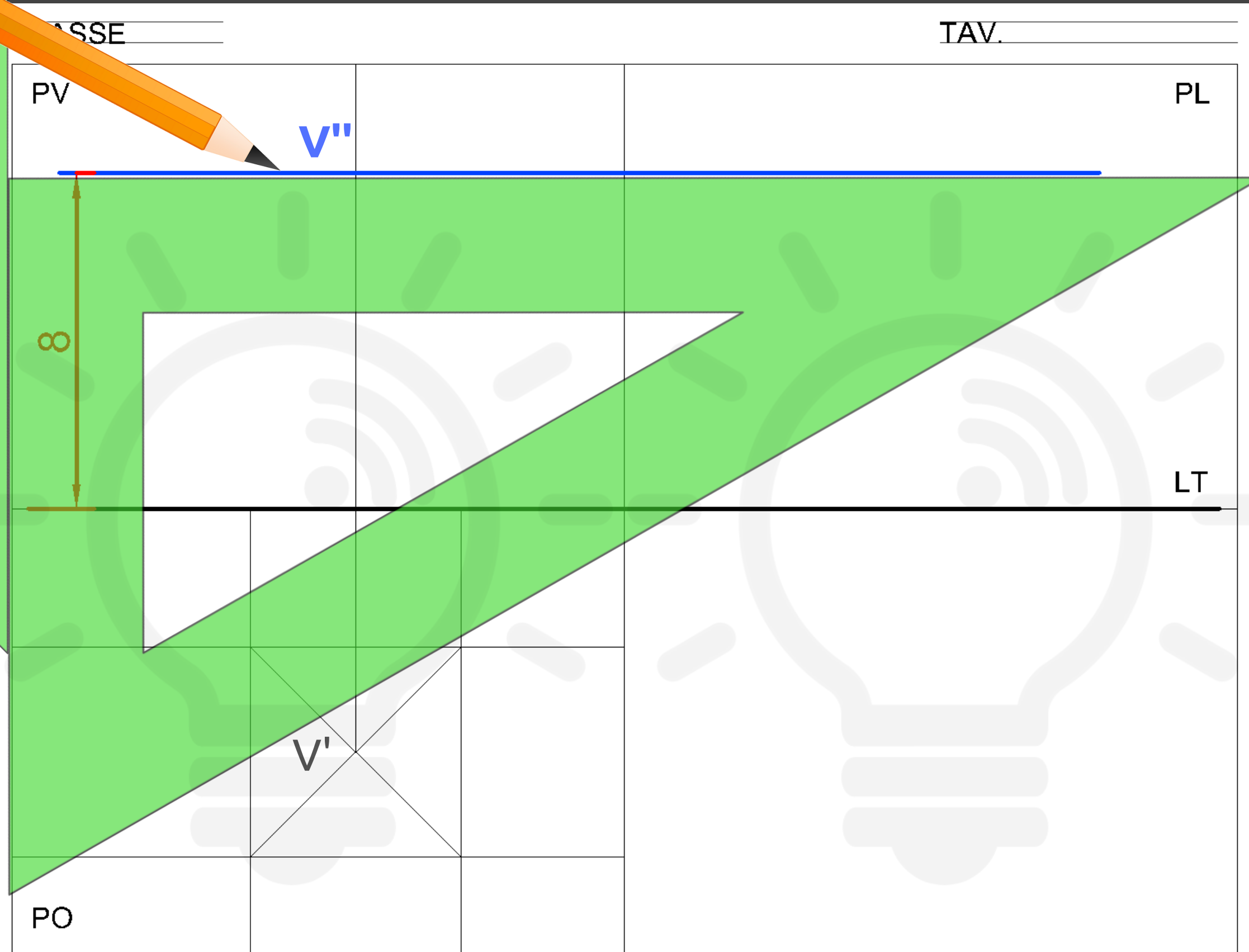

TECNOLOGIA DUEPUNTOZERO

La piramide è alta 8 cm: Traccia una **linea orizzontale distante 8 cm dalla linea di terra per trovare V''**  
(seconda proiezione del vertice)



CLASSE \_\_\_\_\_

TAV. \_\_\_\_\_

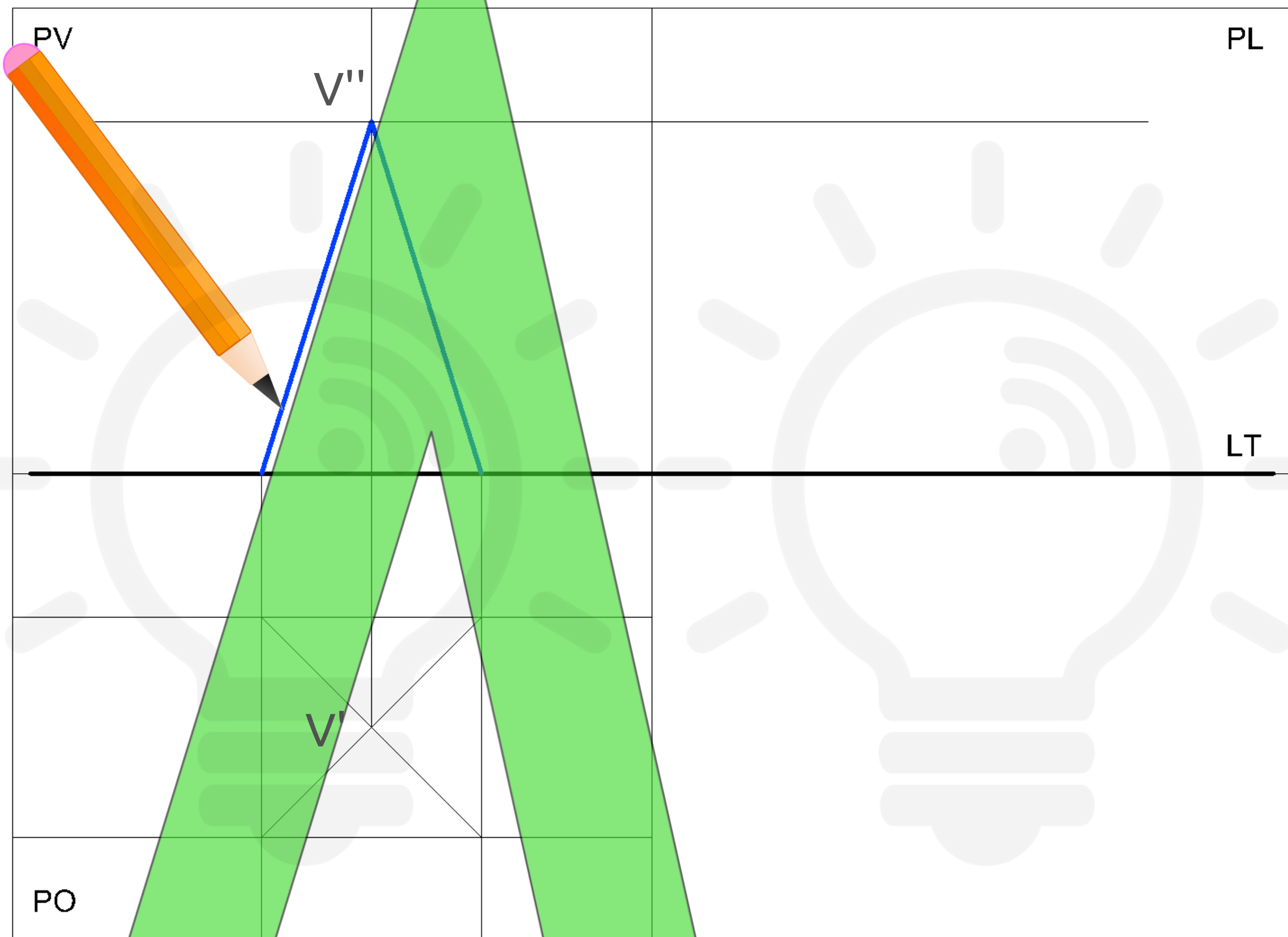

TECNOLOGIA DUEPUNTOZERO

**Completa la vista frontale**





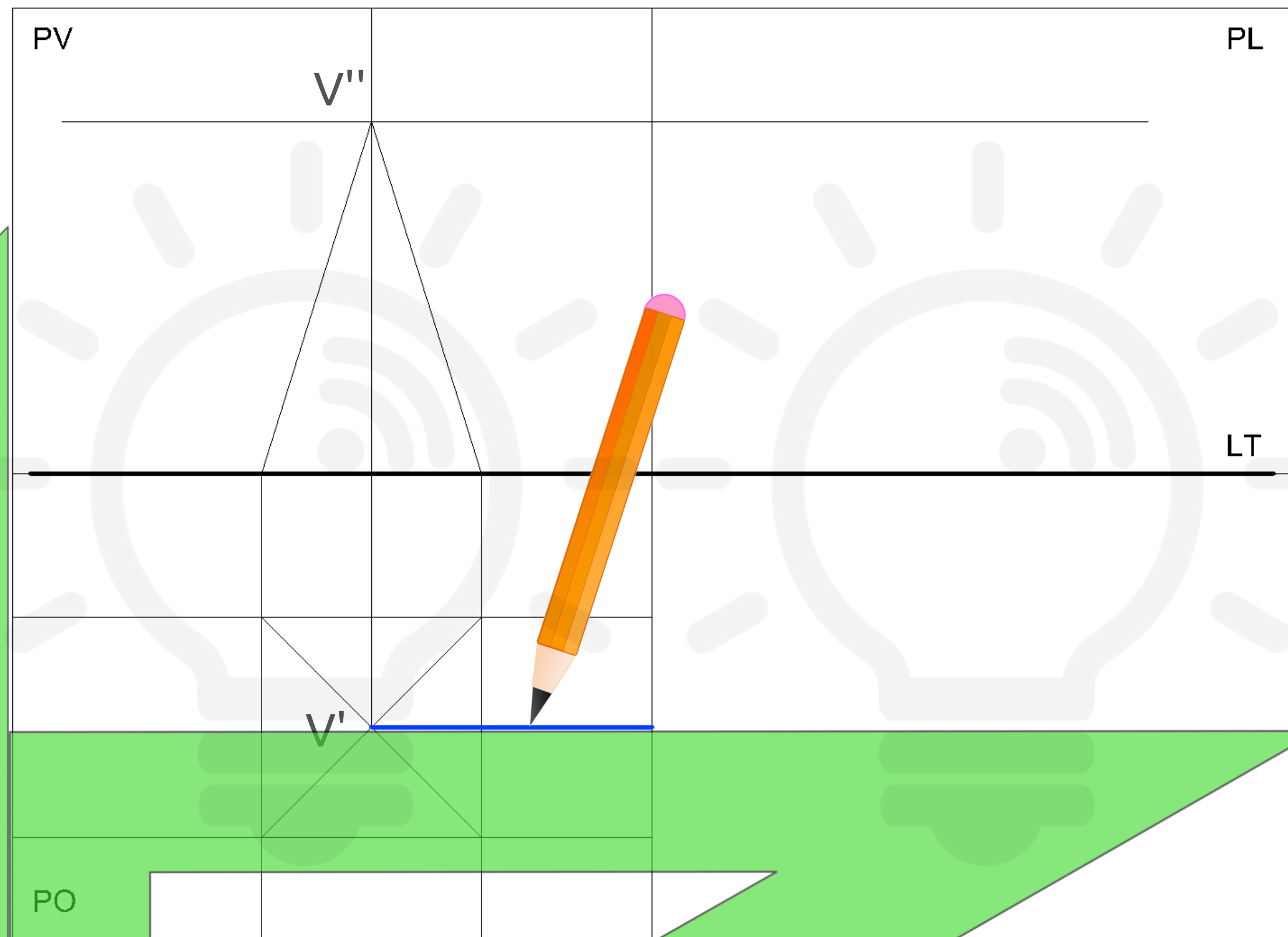

TECNOLOGIA DUEPUNTOZERO



**Traccia le linee di proiezione dalla pianta**  
per costruire la vista vista laterale





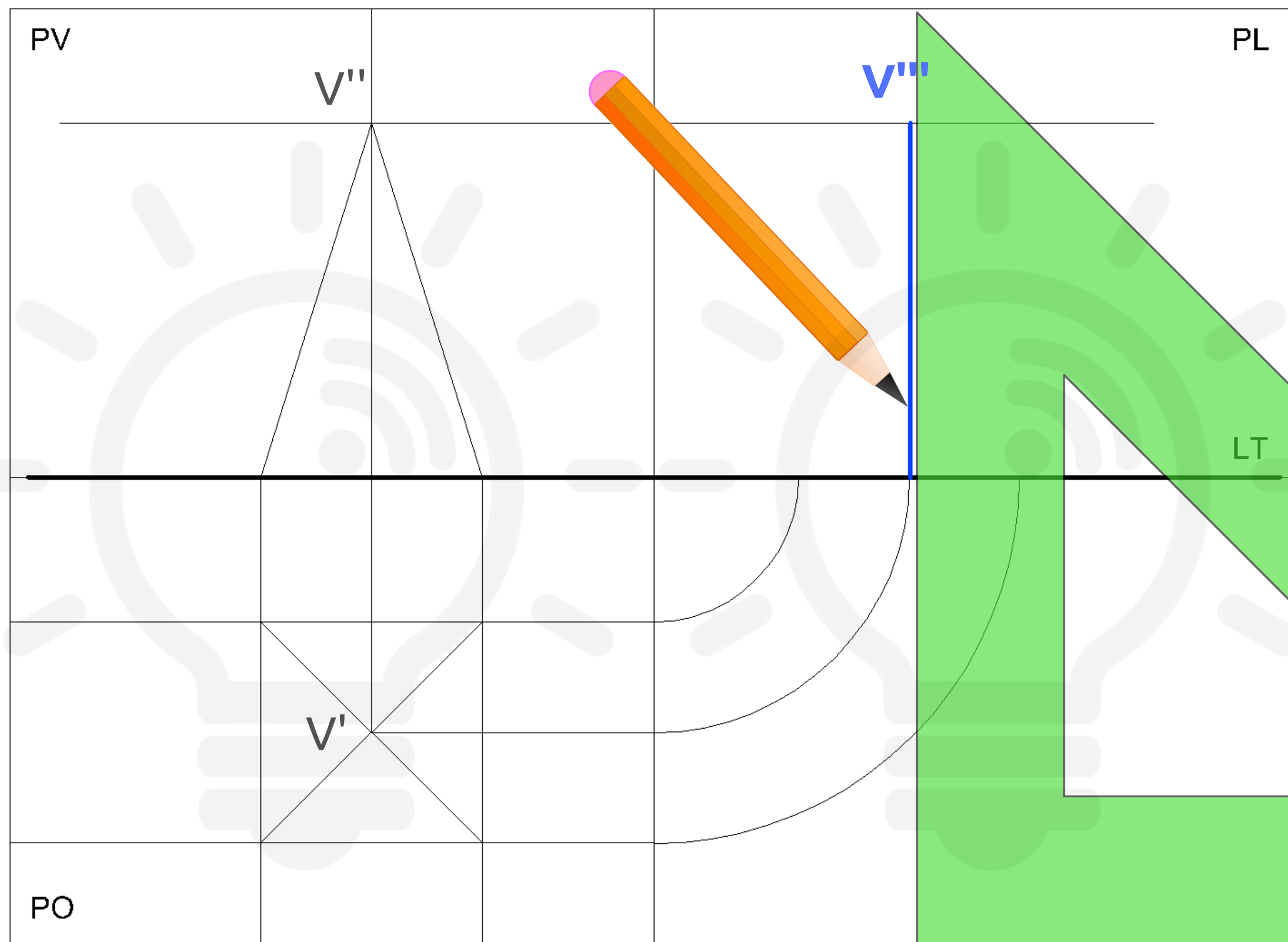

TECNOLOGIA DUEPUNTOZERO

**Trova  $V'''$**  (terza proiezione del vertice)

CLASSE \_\_\_\_\_

TAV. \_\_\_\_\_

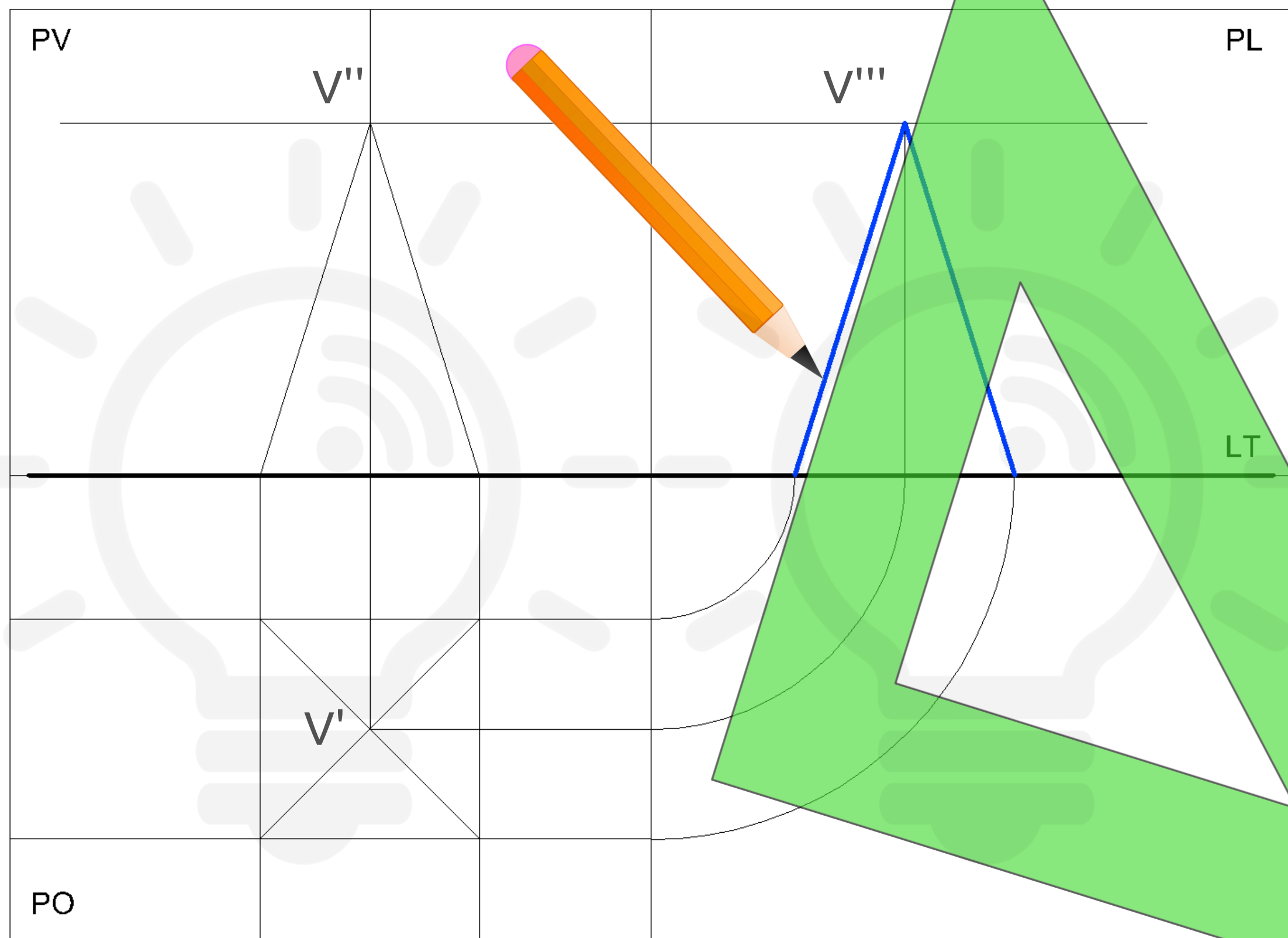

TECNOLOGIA DUEPUNTOZERO

10



Disegna la **vista laterale** della piramide

CLASSE \_\_\_\_\_

TAV. \_\_\_\_\_

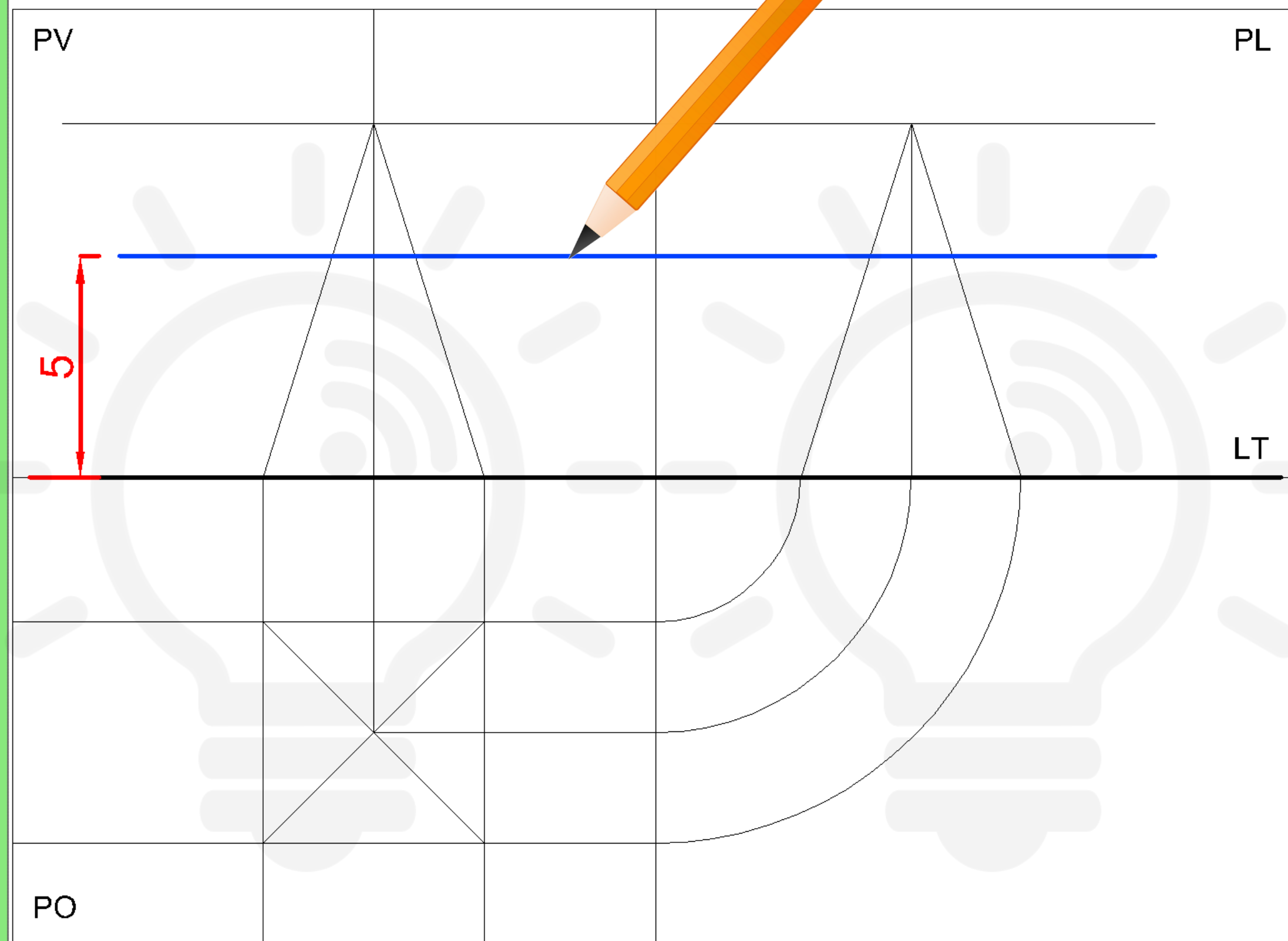

TECNOLOGIA DUEPUNTOZERO

11



Disegna le **tracce del piano di sezione** sul PV e PL  
distanti 5 cm da LT

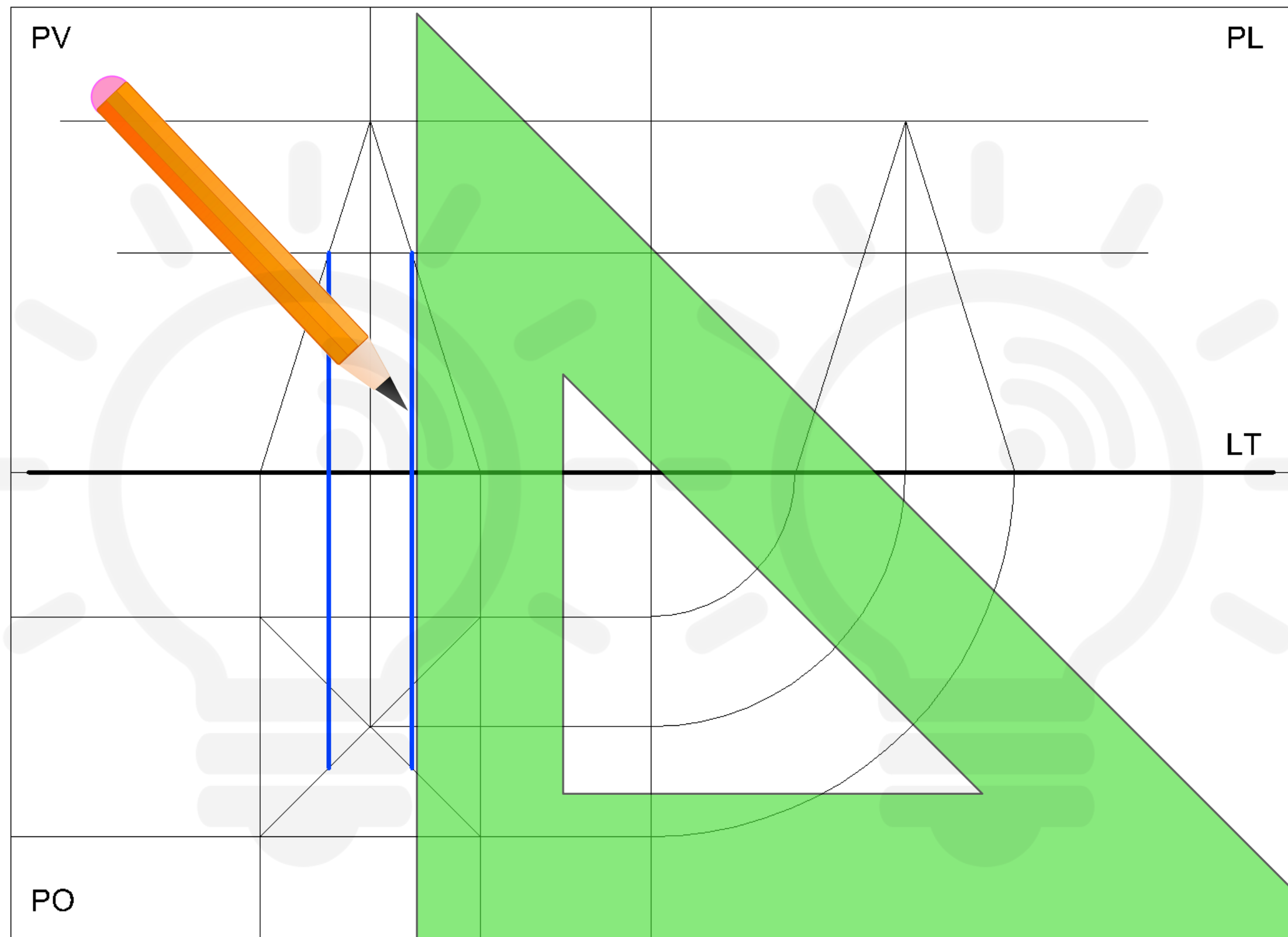

TECNOLOGIA DUEPUNTOZERO

**Traccia le linee di proiezione dal PV**  
per costruire la sezione in pianta

CLASSE \_\_\_\_\_

TAV. \_\_\_\_\_

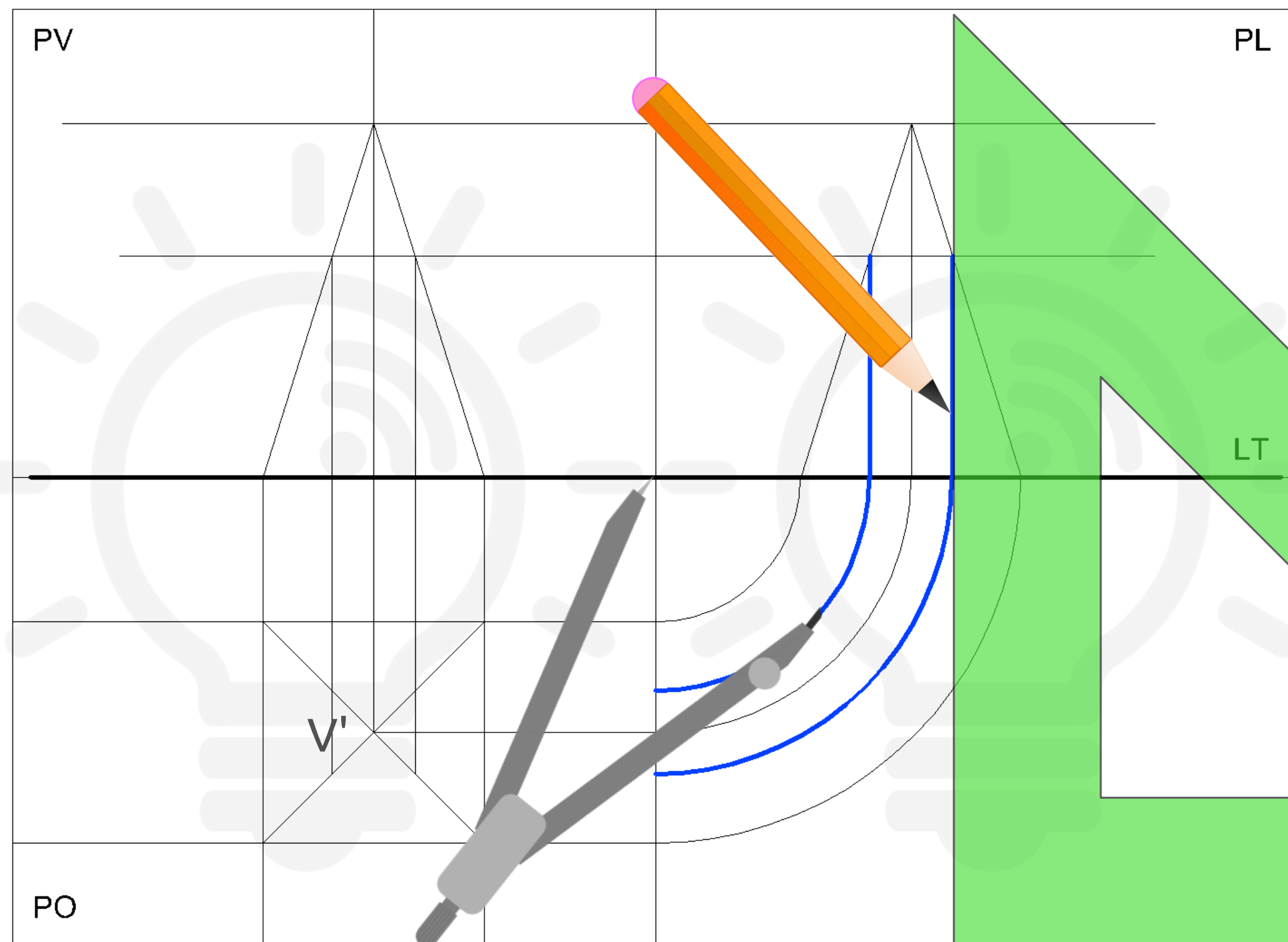

TECNOLOGIA DUEPUNTOZERO

13



**Traccia le linee di proiezione dal PL e ribaltale**  
per costruire la sezione in pianta

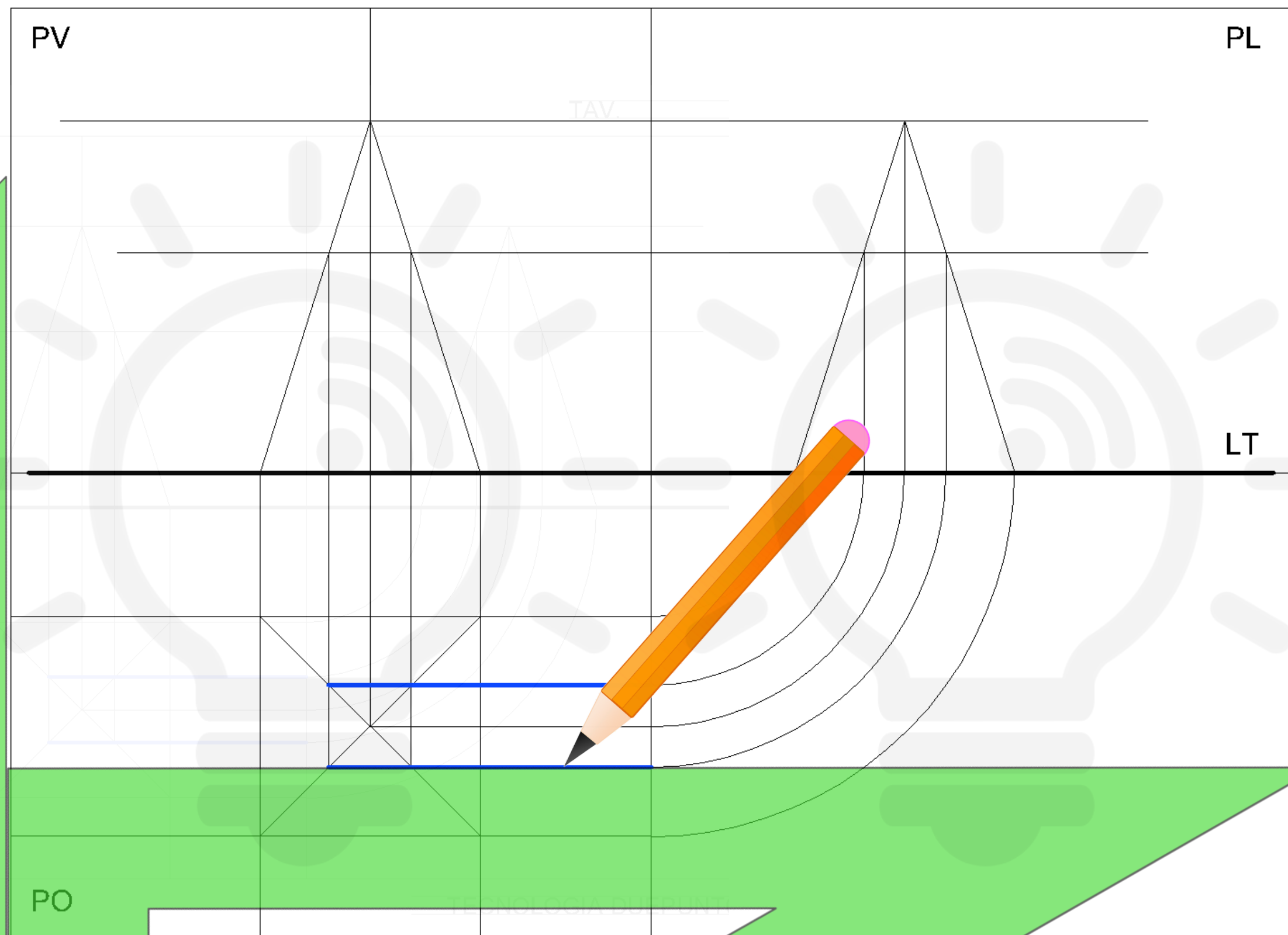

**Traccia le linee di proiezione dal PL e ribaltale**  
per costruire la sezione in pianta





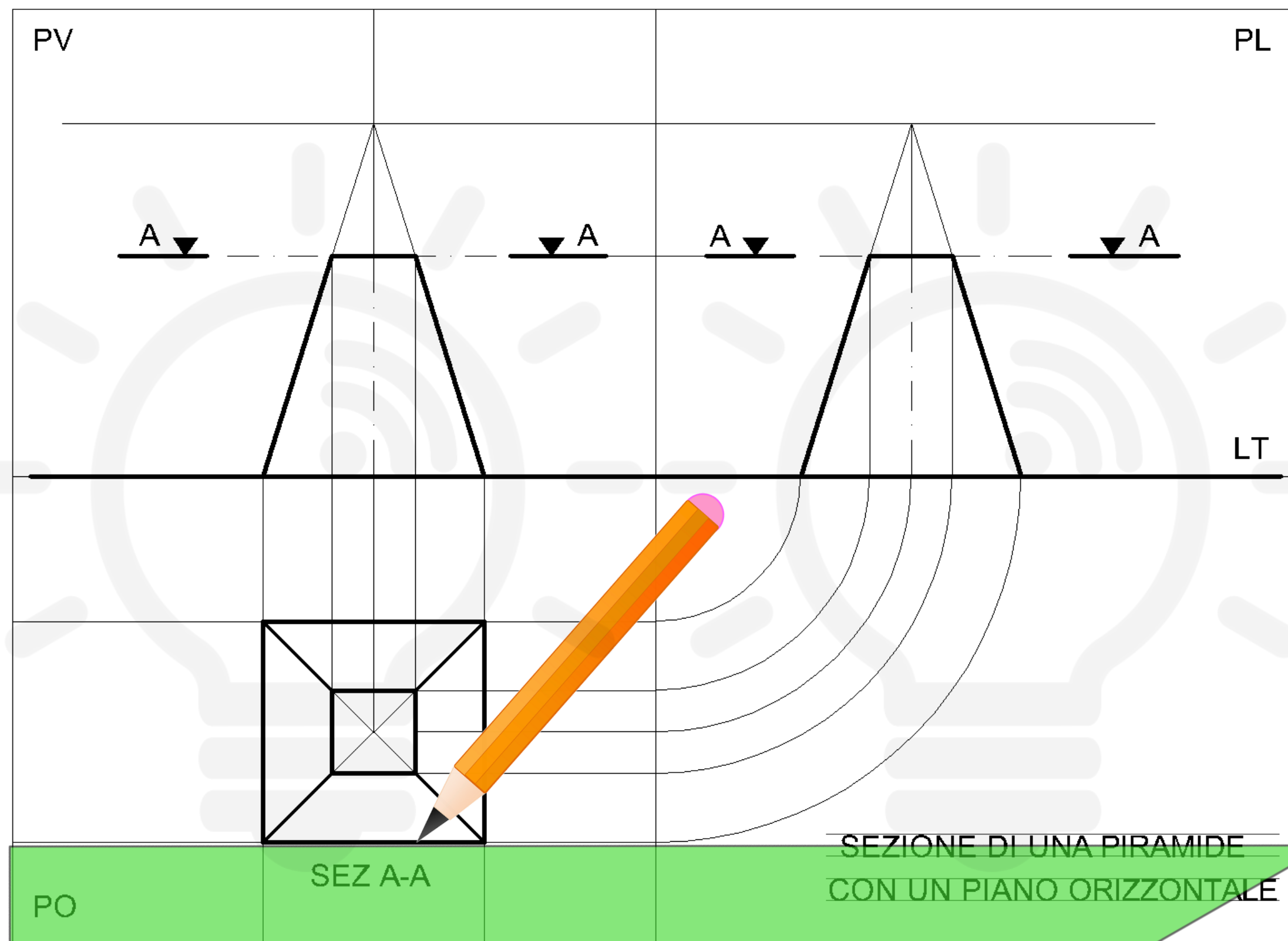

TECNOLOGIA DUEPUNTOZERO

**Ripassa i contorni della piramide sezionata**  
con linea continua grossa e **l'asse** tratto-punto



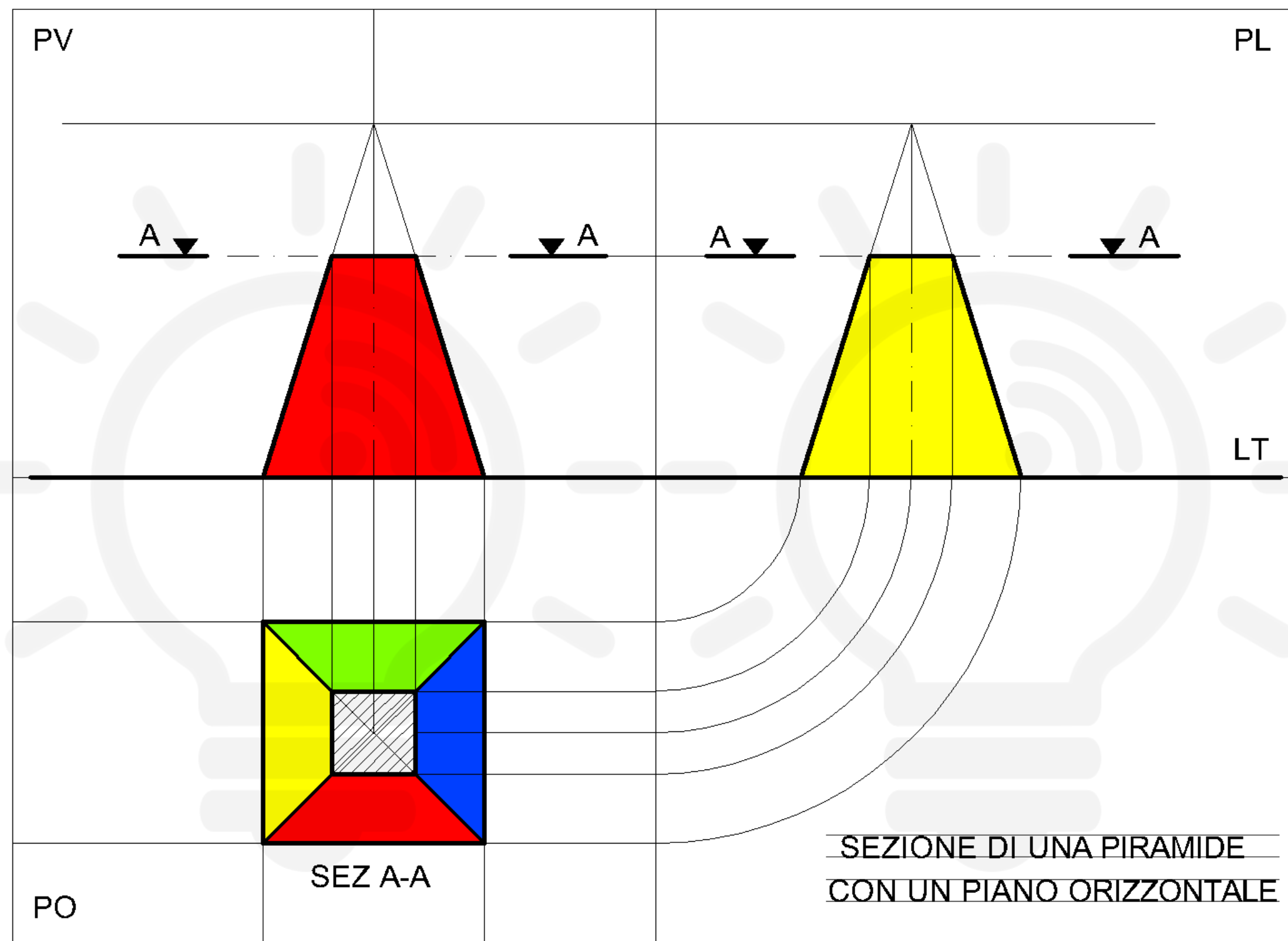

**Colora la piramide con le matite colorate.**  
Metti in evidenza l'area della sezione con una **campitura**.